

RMF-FS AND ASSOCIATED PARTS

MATEABLE BULKHEAD CONNECTORS

BULKHEAD CONNECTORS & MOUNTING REQUIREMENT (MATES TO RMF-FS & RMF-FS-R/A & RMF FS WOC) Dummy Connector RMF-FSD

Part Names: **XSF-BC, XSF-BCL**

Material: Glass Reinforced Epoxy

Contacts: Copper Alloy, Hard Gold Plated per MIL-G-45204

Pressure Rating, Mated: up to 10,000 psi

XSF-BC; Features radial o-ring seal.

XSF-BCL; These connectors feature a locking sleeve provision and utilize a radial o-ring seal.

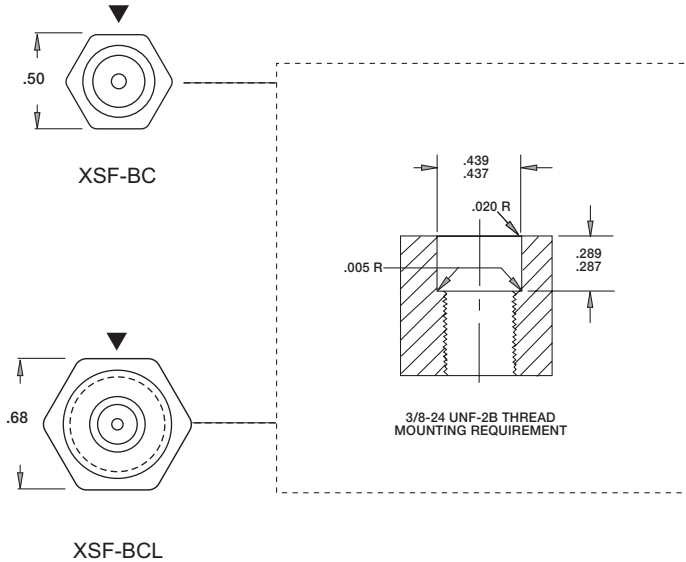
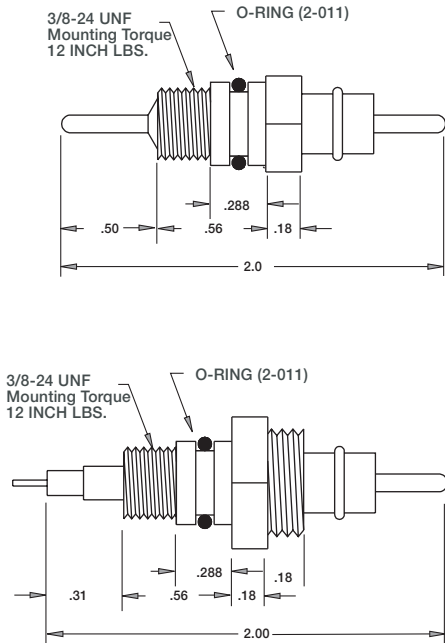

XSF-BC/BCL
COAX
#22 AWG/20 Ω



XSF-1-BC/BCL
1#14



XSF-2-BC/BCL
2#16

Part Name: **XSFDE-BCL**

Material: Glass Reinforced Epoxy

Contacts: Copper Alloy, Hard Gold Plated

Pressure Rating, Mated: up to 10,000 psi

Description: A double-ended connector which accepts a mating connector on either end. The same locking sleeve also fits both ends. This connector utilizes a facial o-ring seal to the bulkhead.

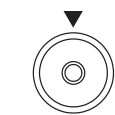

XSF-1-BCLDE
1#14



XSF-2-BCLDE
2#16

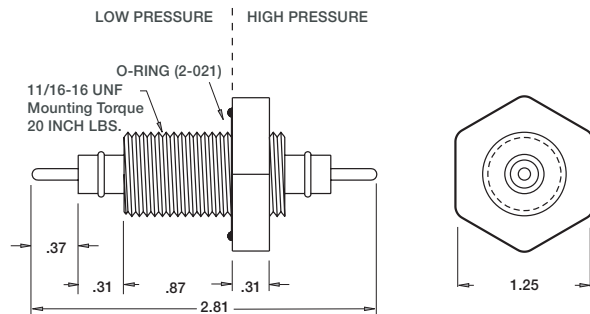

XSFDE-BCL

NOTE: Torque values referenced in this literature assume installation into dry metal threads. Please contact the factory for recommendations.

(FORMERLY KNOWN AS XSDE-BCL)